

# CATTRON NORTH AMERICA



## CANPLUS RT TYPICAL SCHEMATIC

Current Version: D

Drawing Number: 9D08-960-0000-09

HARNESS NUMBER: N/A

WIRE REQUIREMENT: SAE TXL WIRE

J1939 CAN WIRE TWIST REQUIREMENT:Twist rate: 1 twist every 1.5 inches.

WIRE SPLICE REQUIREMENT: ULTRASONIC SPLICE COVERED BY HEAT SHRINK WITH ADHESIVE.

VENDORS CAN CONTACT CATTRON WITH QUESTIONS ABOUT THIS DRAWING.

Please include the drawing number in the subject line of the email.

VARIATION FROM THIS DRAWING IS PROHIBITED WITHOUT WRITTEN CONSENT FROM CATTRON.

### Extended Description:

TYPICAL WIRING AND CONNECTION FOR CUSTOMER REFERENCE ONLY .  
CPs :640,750-E,800,900,1000.

### Revision History

REV	Date	Author	Description
0	2/17/2020	tyreke.hutcherson	Drawing Created
A	4/23/2020	tyreke.hutcherson	Updated signal names, deleted AUX SW, & AUX OUT signals from D21.
B	3/16/2021	Al Sarraf	MODIFIED CP1000 TYPICAL INSTALLATION SCHEMATIC ,NEW 31 PIN CONNECTOR OFFICIAL NAMES AND COLOR CODING ADDED
C	6/23/2022	Al.Sarraf	ADDING CP750-E TYPICAL SCH, MODIFICATION ON OTHERS(SYMBOLS & NOTES CHANGE).
D	1/13/2023	Al.Sarraf	GND ICON ON CP1000 FLTS & AUX STOP MODIFIED , CHARGE CABLE CONFIGURATION ON ALL PAGES REVISED .

Title: CANPLUS RT TYPICAL SCHEMATIC | Size: B

Document Name: Cover page

Sheet: 1 of 6	Date: 2/17/2020	DrawnBy: Al.Sarraf
---------------	-----------------	--------------------

<b>CATTRON NORTH AMERICA</b>	
20 MANSELL Ct.E SUITE 350 ROSWELL,GA 30075 USA	

PROPRIETARY AND CONFIDENTIAL  
CATTRON NORTH AMERICA. All Copyright and Trademark Rights Reserved.  
THE INFORMATION CONTAINED IN THIS DRAWING IS THE SOLE PROPERTY OF CATTRON NORTH AMERICA.  
REPRODUCTION IN PART OR AS A WHOLE WITHOUT THE WRITTEN PERMISSION OF CATTRON NORTH AMERICA. IS PROHIBITED.

# TYPICAL CONNECTIONS CP640 (CURRENTLY ELECTRONIC ONLY)

DRAWING (FOR REFERENCE ONLY) SHOWN IS A TYPICAL SETUP  
INPUTS AND OUTPUTS WILL BE CONFIGURED BASED ON APPLICATION

Drawing History	
Current Version: D	

### LOFA PANEL TO ENGINE

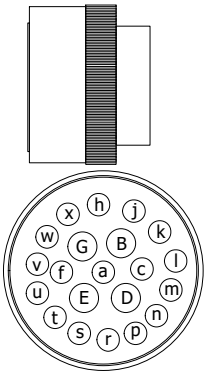

21 POSITION CONNECTOR  
TE CONNECTIVITY: HDP26-24-21SE

TE Connectivity  
HDP26-24-21SE

a	Red	12 AWG	BATTERY(+)
b	Black	16 AWG	SENDER RETURN
c	Red   Black	18 AWG	STARTER
d	Black	12 AWG	GROUND
e	Black	18 AWG	CAN SHIELD
f	Violet	14 AWG	ECU
g	Pink   Black	16 AWG	IGNITION
h	White   Black	16 AWG	AUX OUTPUT
i	Yellow   Black	16 AWG	AUX SWITCH 2
j	Blue   Orange	16 AWG	TEMPERATURE/OIL (SENDER/SWITCH)
k	Green	18 AWG	CAN L
l	Yellow	18 AWG	CAN H
m	Yellow	16 AWG	AUX SWITCH 1
n	Green   Black	16 AWG	BLUE LEVEL SENDER
o			
p			
q			
r			
s			
t			
u			
v			
w			
x			

Conn Deutsch HDP 21 Pos Fem (HDP26-24-21SE)

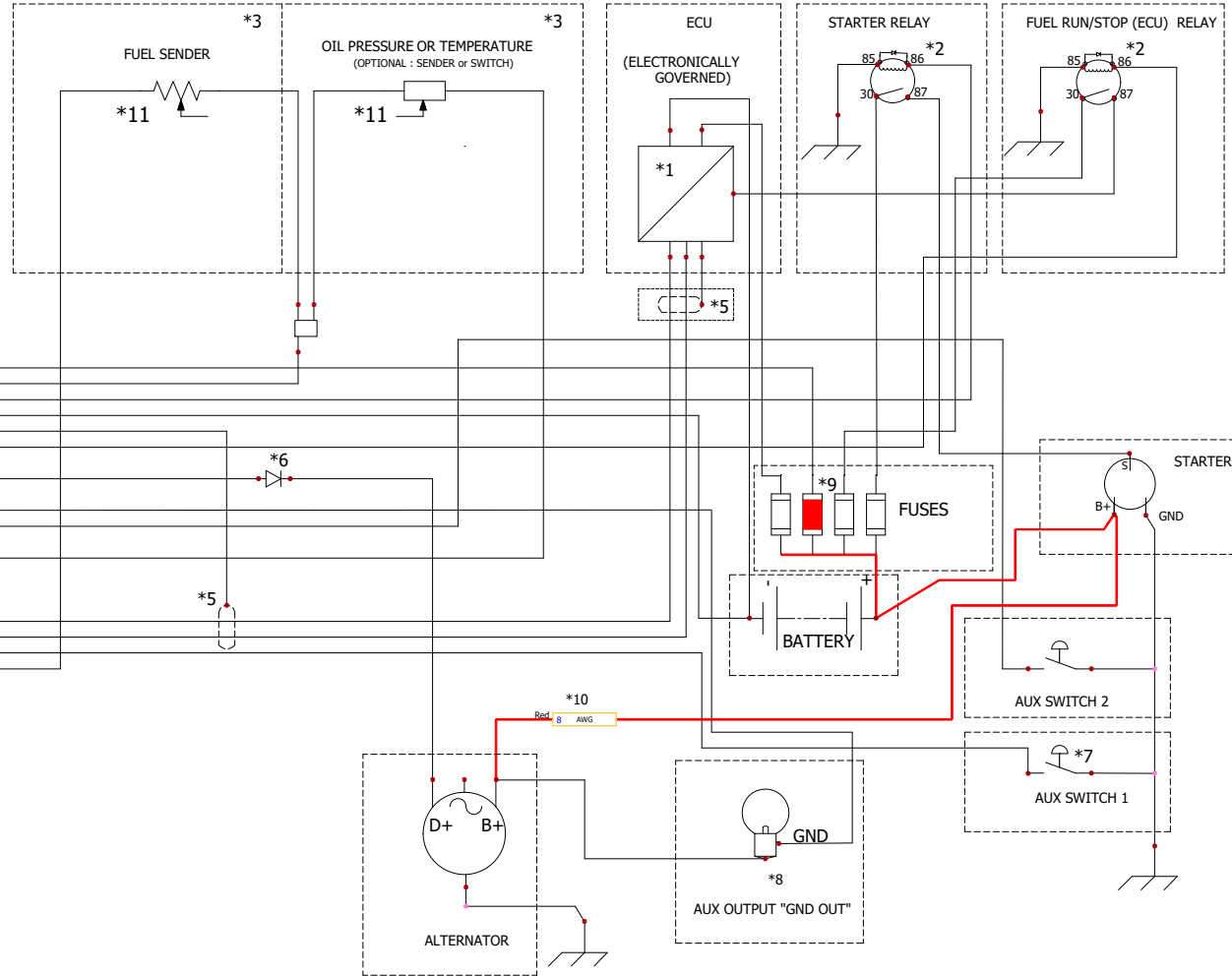

### NOTES:

- \*1 - ENGINE ECU (REFER TO MANUFACTURER DOCUMENTATION).
- \*2 - RELAY (WITH SUPPRESSION DIODE) MUST BE USED.
- \*3 - IT IS REQUIRED THAT THE SENDER RETURN CONNECTION (PIN:C) BE CONNECTED TO A GROUND POINT AS CLOSE TO THE SENDER AS POSSIBLE FOR BEST ACCURACY.
- \*4 - DENOTES TWISTED PAIR: 120 OHM CAN TERMINATING RESISTOR IN THE CP PANEL.
- \*5 - DENOTES CAN SHIELD: SHIELDED CABLE OR TRIPLE TWISTED (GROUNDED ON ONE SIDE).
- \*6 - INSTALL BLOCKING DIODE TO PROTECT ELECTRONIC COMPONENTS.
- \*7 - OPTIONAL CONFIGURABLE INPUT.
- \*8 - OPTIONAL CONFIGURABLE OUTPUT.
- \*9 - INSTALL APPROPRIATELY SIZED FUSE OR CIRCUIT BREAKER, 30A FUSE REQUIRED FOR CP PANEL.
- \*10 - TYPICAL 8AWG CHARGE WIRE (REFER TO MANUFACTURER DOCUMENTATION).
- \*11 - OPTIONAL CONFIGURABLE SENDER, CONFIGURABLE BY CUSTOMIZER SOFTWARE ,FOR MORE INFORMATION CONTACT CATTRON SUPPORT GROUP .

Title: CANPLUS RT TYPICAL SCHEMATIC		Size: B	
Document Name: 9D08-960-0000-09_CP640 TYPICAL CONNECTION			
Sheet: 2	of 6	Date: 2/17/2020	DrawnBy: Al.Sarraf
<b>CATTRON NORTH AMERICA</b> 20 MANSELL Ct.E SUITE 350 ROSWELL,GA 30075 USA			

# TYPICAL CONNECTIONS CP750-E (ELECTRONIC AND MECHANICAL)

DRAWING (FOR REFERENCE ONLY) SHOWN IS A TYPICAL SETUP  
INPUTS AND OUTPUTS WILL BE CONFIGURED BASED ON APPLICATION

### NOTES:

- \*1 - ENGINE ECU (REFER TO MANUFACTURER DOCUMENTATION).
- \*2 - RELAY (WITH SUPPRESSION DIODE) MUST BE USED.
- \*3 - IT IS REQUIRED THAT THE SENDER RETURN CONNECTION (PIN-C) BE CONNECTED TO A GROUND POINT, AS CLOSE TO THE SENDER AS POSSIBLE FOR BEST ACCURACY.
- \*4 - CANBUS TWISTED PAIR, 120Ω CAN TERMINATING RESISTOR IN THE CP PANEL.
- \*5 - DENOTES CAN SHIELD: SHIELDED CABLE OR TRIPLE TWISTED (GROUNDED ON ONE SIDE).
- \*6 - INSTALL BLOCKING DIODE TO PROTECT ELECTRONIC COMPONENTS.
- \*7 - OPTIONAL CONFIGURABLE INPUT.
- \*8 - OPTIONAL CONFIGURABLE OUTPUT.
- \*9 - INSTALL APPROPRIATELY SIZED FUSE OR CIRCUIT BREAKER, 30A FUSE REQUIRED FOR CP PANEL.
- \*10 - TYPICAL 8AWG CHARGE WIRE (REFER TO MANUFACTURER DOCUMENTATION).
- \*11 - OPTIONAL 2 WIRE OR 3 WIRE TRANSDUCER.
- \*12 - MECHANICAL ONLY
- \*13 - CAN PLUS WIRES SHOULD BE TERMINATED ON ACTUATOR SIDE BY 120Ω RESISTOR FOR MECHANICAL APPLICATIONS.
- \*14 - MORE DETAILS ARE AVAILABLE IN INSTALLATION MANUAL.

### LOFA PANEL TO ENGINE

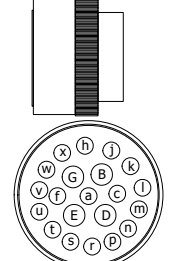

21 POSITION CONNECTOR  
TE CONNECTIVITY: HDP26-24-21SE

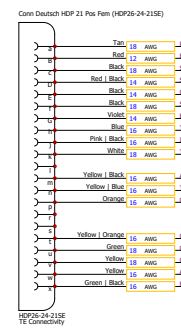

### AUX I/O INTERFACE 801-0410-92

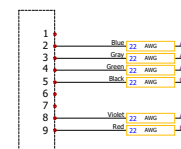

### AUTO SWITCH INTERFACE

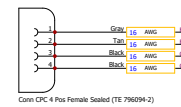

### 4-20 mA INTERFACES

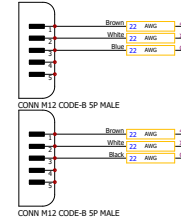

### MODBUS INTERFACES

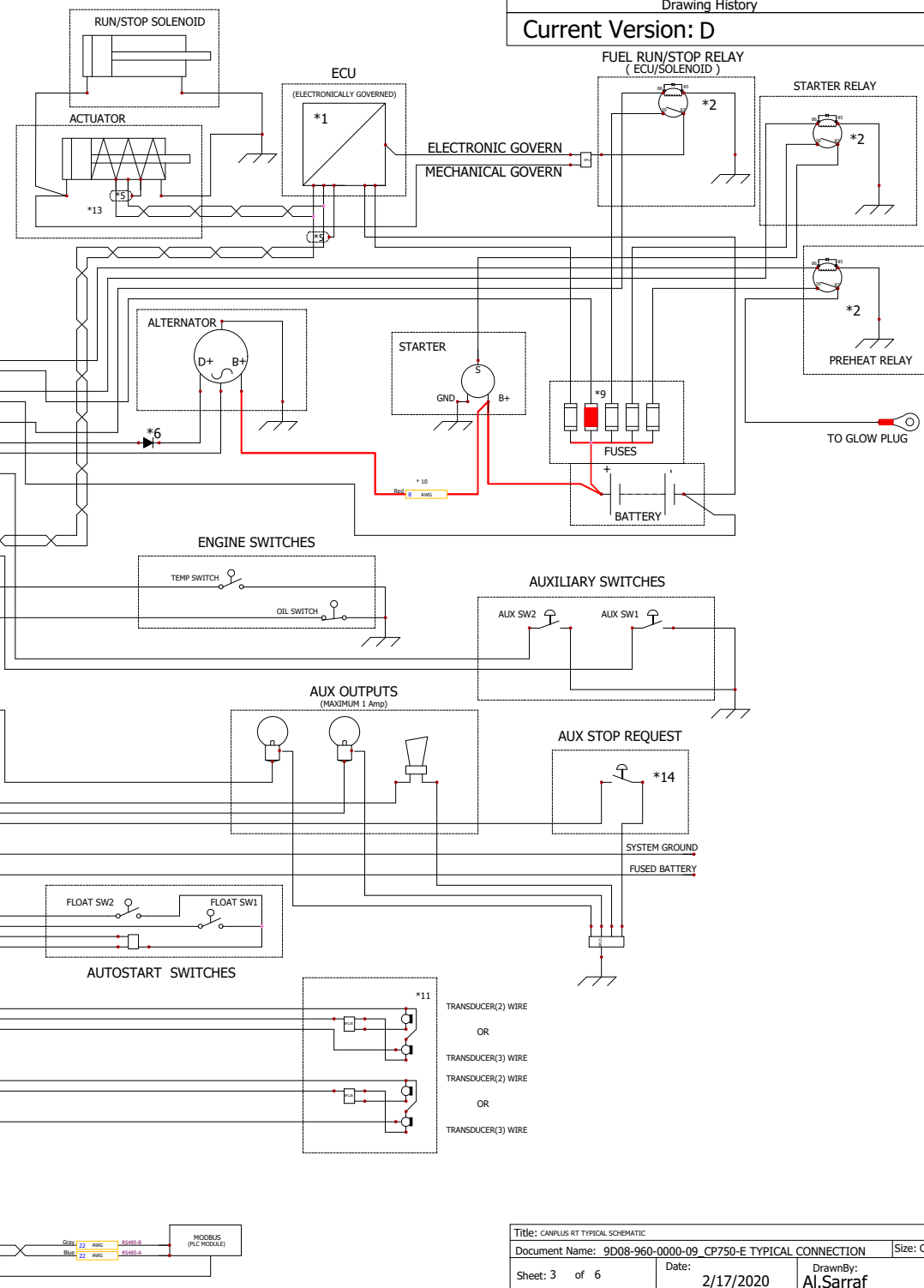
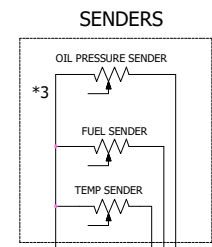
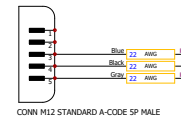

Title: CANPLUS RT TYPICAL SCHEMATIC		
Document Name: 9D08-960-0000-09 CP750-E TYPICAL CONNECTION	Size: C	
Sheet: 3 of 6	Date: 2/17/2020	DrawnBy: Al.Sarraf
CATTRON NORTH AMERICA 20 MANSELL CLE SUITE 350 ROSWELL, GA 30075 USA		

# TYPICAL CONNECTIONS CP800 (CURRENTLY ELECTRONIC ONLY)

DRAWING (FOR REFERENCE ONLY) SHOWN IS A TYPICAL SETUP

INPUTS AND OUTPUTS WILL BE CONFIGURED BASED ON APPLICATION

Drawing History

Current Version: D

### NOTES:

- \*1 - ENGINE ECU (REFER TO MANUFACTURER DOCUMENTATION).
- \*2 - RELAY (WITH SUPPRESSION DIODE) MUST BE USED.
- \*3 - IT IS REQUIRED THAT THE SENDER RETURN CONNECTION(PIN:C) BE CONNECTED TO A GROUND POINT AS CLOSE TO THE SENDER AS POSSIBLE FOR BEST ACCURACY.
- \*4 - DENOTES TWISTED PAIR: 120 OHM CAN TERMINATING RESISTOR IN THE CP PANEL.
- \*5 - DENOTES CAN SHIELD: SHIELDED CABLE OR TRIPLE TWISTED (GROUNDED ON ONE SIDE).
- \*6 - INSTALL BLOCKING DIODE TO PROTECT ELECTRONIC COMPONENTS.
- \*7 - OPTIONAL CONFIGURABLE INPUT.
- \*8 - OPTIONAL CONFIGURABLE OUTPUT.
- \*9 - INSTALL APPROPRIATELY SIZED FUSE OR CIRCUIT BREAKER,30A FUSE REQUIRED FOR CP PANEL.
- \*10 - TYPICAL 8AWG CHARGE WIRE (REFER TO MANUFACTURER DOCUMENTATION).
- \*11 - OPTIONAL CONFIGURABLE SENDER/SWITCHES, CONFIGURABLE BY CUSTOMIZER SOFTWARE, FOR MORE INFORMATION CONTACT CATTRON SUPPORT GROUP .
- \*12 - OPTIONAL 2 WIRE OR 3 WIRE TRANSDUCER.

### LOFA PANEL TO ENGINE

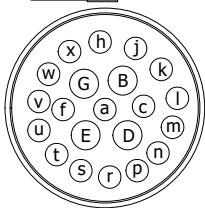
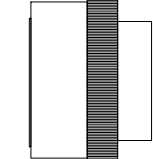

21 POSITION CONNECTOR  
TE CONNECTIVITY: HDP26-24-21SE

### AUTO SWITCH INTERFACE

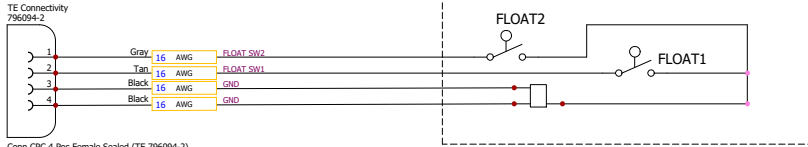

Conn CPC 4 Pos Female Sealed (TE 796004-2)

### 4-20 mA INTERFACE

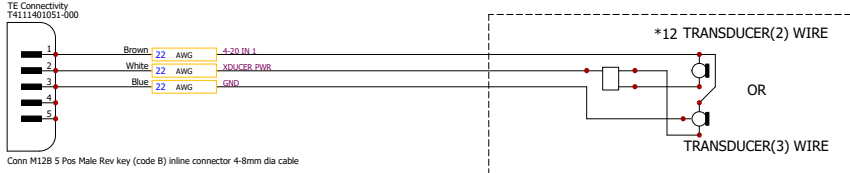

Conn M12B 5 Pos Male Rev key (code B) inline connector 4-8mm dia cable

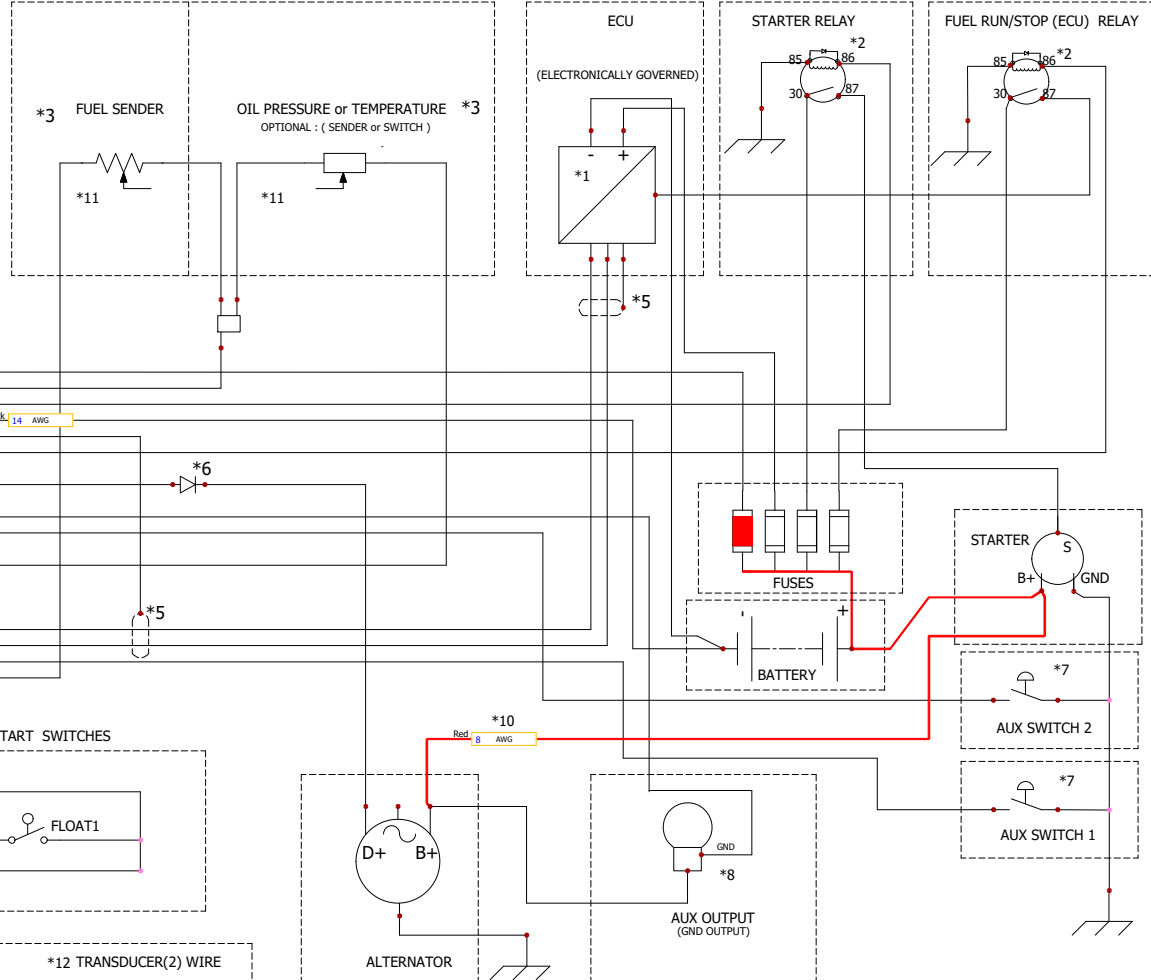

Title: CANPLUS RT TYPICAL SCHEMATIC      Size: B

Document Name: 9D08-960-0000-09\_CP800 TYPICAL CONNECTION

Sheet: 4 of 6      Date: 2/17/2020      DrawnBy: Al.Sarraf

**CATTRON NORTH AMERICA**

20 MANSELL Ct.E SUITE 350  
ROSWELL,GA 30075 USA

PROPRIETARY AND CONFIDENTIAL  
 CATTRON NORTH AMERICA. All Copyright and Trademark Rights Reserved.  
 THE INFORMATION CONTAINED IN THIS DRAWING IS THE SOLE PROPERTY OF CATTRON .  
 REPRODUCTION IN PART OR AS A WHOLE WITHOUT THE WRITTEN PERMISSION OF CATTRON NORTH AMERICA. IS PROHIBITED.

# TYPICAL CONNECTIONS CP900 (ELECTRONIC AND MECHANICAL)

DRAWING (FOR REFERENCE ONLY) SHOWN IS A TYPICAL SETUP  
INPUTS AND OUTPUTS WILL BE CONFIGURED BASED ON APPLICATION

### NOTES:

- \*1 - ENGINE ECU (REFER TO MANUFACTURER DOCUMENTATION).
- \*2 - RELAY (WITH SUPPRESSION DIODE) MUST BE USED.
- \*3 - IT IS REQUIRED THAT THE SENDER RETURN CONNECTION(PIN:C) BE CONNECTED TO A GROUND POINT AS CLOSE TO THE SENDER AS POSSIBLE FOR BEST ACCURACY.
- \*4 - DENOTES TWISTED PAIR: 120 OHM CAN TERMINATING RESISTOR IN THE CP PANEL.
- \*5 - DENOTES CAN SHIELD: SHIELDED CABLE OR TRIPLE TWISTED (GROUNDED ON ONE SIDE).
- \*6 - INSTALL BLOCKING DIODE TO PROTECT ELECTRONIC COMPONENTS.
- \*7 - OPTIONAL CONFIGURABLE INPUT.
- \*8 - OPTIONAL CONFIGURABLE OUTPUT.
- \*9 - INSTALL APPROPRIATELY SIZED FUSE OR CIRCUIT BREAKER, 30A FUSE REQUIRED FOR CP PANEL.
- \*10 - TYPICAL 8AWG CHARGE WIRE (REFER TO MANUFACTURER DOCUMENTATION).
- \*11 - OPTIONAL 2 WIRE OR 3 WIRE TRANSDUCER.
- \*12 - MECHANICAL ONLY
- \*13 - OPTIONAL CONFIGURABLE SENDER/SWITCHES, CONFIGURABLE BY CUSTOMIZER SOFTWARE, FOR MORE INFORMATION CONTACT CATTRON SUPPORT GROUP.
- \*14 - CAN PLUS WIRES SHOULD BE TERMINATED ON ACTUATOR SIDE FOR MECHANICAL APPLICATIONS.

Drawing History

Current Version: D

### LOFA PANEL TO ENGINE

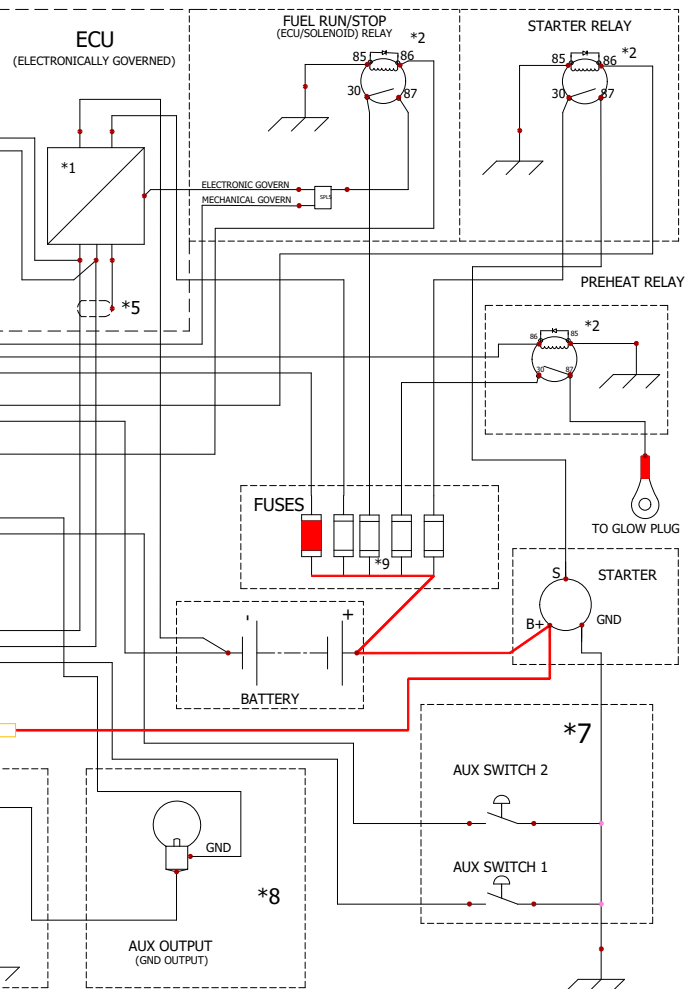
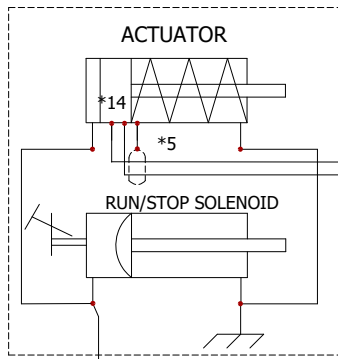
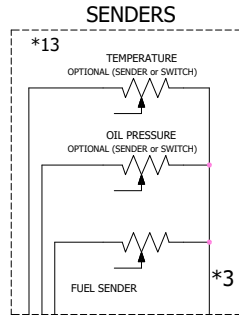
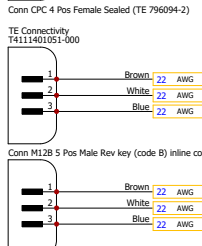
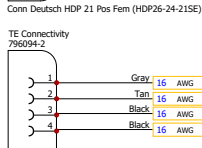
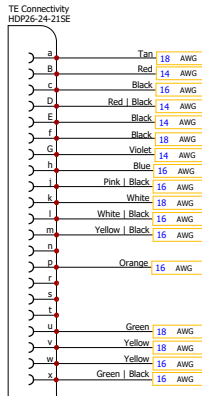
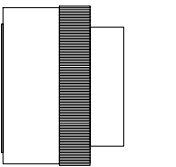

21 POSITION CONNECTOR

TE CONNECTIVITY: HDP26-24-21SE

AUTO SWITCH INTERFACE

4-20 mA INTERFACES

Title: CANPLUS RT TYPICAL SCHEMATIC Size: B

Document Name: 9D08-960-0000-09\_CP900 TYPICAL CONNECTION

Sheet: 5 of 6 Date: 2/17/2020 DrawnBy: Al.Sarraf

**CATTRON NORTH AMERICA**

20 MANSELL Ct.E SUITE 350  
ROSWELL, GA 30075 USA

PROPRIETARY AND CONFIDENTIAL  
 CATTRON NORTH AMERICA. All Copyright and Trademark Rights Reserved.  
 THE INFORMATION CONTAINED IN THIS DRAWING IS THE SOLE PROPERTY OF CATTRON.  
 REPRODUCTION IN PART OR AS A WHOLE WITHOUT THE WRITTEN PERMISSION OF CATTRON NORTH AMERICA. IS PROHIBITED.

# TYPICAL CONNECTIONS CP1000 (ELECTRONIC AND MECHANICAL)

DRAWING (FOR REFERENCE ONLY) SHOWN IS A TYPICAL SETUP  
 INPUTS AND OUTPUTS WILL BE CONFIGURED BASED ON APPLICATION

## NOTES:

- \*1 - ENGINE ECU (REFER TO MANUFACTURER DOCUMENTATION).
- \*2 - RELAY (WITH SUPPRESSION DIODE) MUST BE USED.
- \*3 - IT IS REQUIRED THAT THE SENDER RETURN CONNECTION (PIN-C) BE CONNECTED TO A GROUND POINT AS CLOSE TO THE SENDER AS POSSIBLE FOR BEST ACCURACY.
- \*4 - DENOTES TWISTED PAIR: 120Ω CAN TERMINATING RESISTOR IN THE CP PANEL.
- \*5 - DENOTES CAN SHIELD: SHIELDED CABLE OR TRIPLE TWISTED (GROUNDED ON ONE SIDE).
- \*6 - INSTALL BLOCKING DIODE TO PROTECT ELECTRONIC COMPONENTS.
- \*7 - OPTIONAL CONFIGURABLE INPUT.
- \*8 - OPTIONAL CONFIGURABLE OUTPUT.
- \*9 - INSTALL APPROPRIATELY SIZED FUSE OR CIRCUIT BREAKER, 30A FUSE REQUIRED FOR CP PANEL.
- \*10 - TYPICAL 8AWG CHARGE WIRE (REFER TO MANUFACTURER DOCUMENTATION).
- \*11 - OPTIONAL 2 WIRE OR 3 WIRE TRANSDUCER.
- \*12 - ELECTROMAGNETIC PULSE FLOW METER CONFIGURABLE.
- \*13 - MECHANICAL ONLY.
- \*14 - CAN PLUS WIRES SHOULD BE TERMINATED ON ACTUATOR SIDE BY 120Ω RESISTOR FOR MECHANICAL APPLICATIONS.
- \*15 - MORE DETAILS ARE AVAILABLE IN INSTALLATION MANUAL.

### LOFA PANEL TO ENGINE

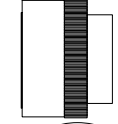

21 POSITION CONNECTOR  
 TE CONNECTIVITY: HDP26-24-21SE

A	TRN	18	AVG	WIREBKT
B	Red	12	AVG	BATT(BUS)
C	Black	18	AVG	SENDER RETURN
D	Red	18	AVG	START/STOP
E	Black	18	AVG	IGNITION
F	Black	18	AVG	LEAK SENS/D
G	White	14	AVG	RECHARGE/IGN/D
H	Black	18	AVG	TEMP SENS/D
I	White	18	AVG	IGNITION
J	White	18	AVG	RECHARGE/IGN/D
K	White	18	AVG	RECHARGE/IGN/D
L	Yellow	18	AVG	STOP SWITCH
M	Orange	18	AVG	IGN. PROTECT SW/SPARE
N	White	18	AVG	RECHARGE GROUP
O	Yellow	18	AVG	IGN. SWITCH
P	Green	18	AVG	LEAK SENS
Q	Yellow	18	AVG	LOW FRESH
R	Green	18	AVG	FUEL SENS/D
S	Green	18	AVG	FUEL SENS/D
T	Green	18	AVG	FUEL SENS/D

Conn Deutsch HDP 31 Pos Fem (HDP26-24-21SE)  
 TE Connectivity HDP26-24-21SE

### INPUT/OUTPUT CONNECTOR

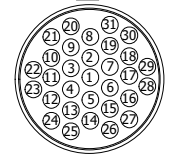
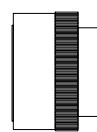

31 POSITION CONNECTOR  
 TE CONNECTIVITY: HDP25-24-31SE

1	White	18	AVG	AUX SW1
2	White	18	AVG	AUX SW2
3	White	18	AVG	AUX SW3
4	White	18	AVG	AUX SW4
5	White	18	AVG	AUX SW5
6	White	18	AVG	AUX SW6
7	Red	18	AVG	AUX OUT 1 SOURCE
8	Red	18	AVG	AUX OUT 1 SOURCE
9	Red	18	AVG	AUX OUT 1
10	Red	18	AVG	AUX OUT 1
11	Yellow	18	AVG	AUX OUT 2
12	Yellow	18	AVG	AUX OUT 2 SOURCE
13	White	18	AVG	IGN SW
14	White	18	AVG	IGN SW
15	White	18	AVG	AUX IN/IGNITION OUT
16	White	18	AVG	AUX OUT 3
17	White	18	AVG	AUX OUT 4
18	White	18	AVG	IGNITION TRANSDUCER POWER
19	White	18	AVG	IGNITION TRANSDUCER POWER
20	White	18	AVG	AUX SW1
21	Black	18	AVG	IGN SW
22	White	18	AVG	AUX SW1
23	White	18	AVG	AUX SW2
24	White	18	AVG	TRANSDUCER 1
25	White	18	AVG	TRANSDUCER 2
26	White	18	AVG	TRANSDUCER 3
27	White	18	AVG	TRANSDUCER 4
28	White	18	AVG	TRANSDUCER 5
29	White	18	AVG	TRANSDUCER 6
30	White	18	AVG	AUX SW1
31	Green	18	AVG	AUX SW1

Conn Deutsch 31 Pos Fem Threaded for backshell

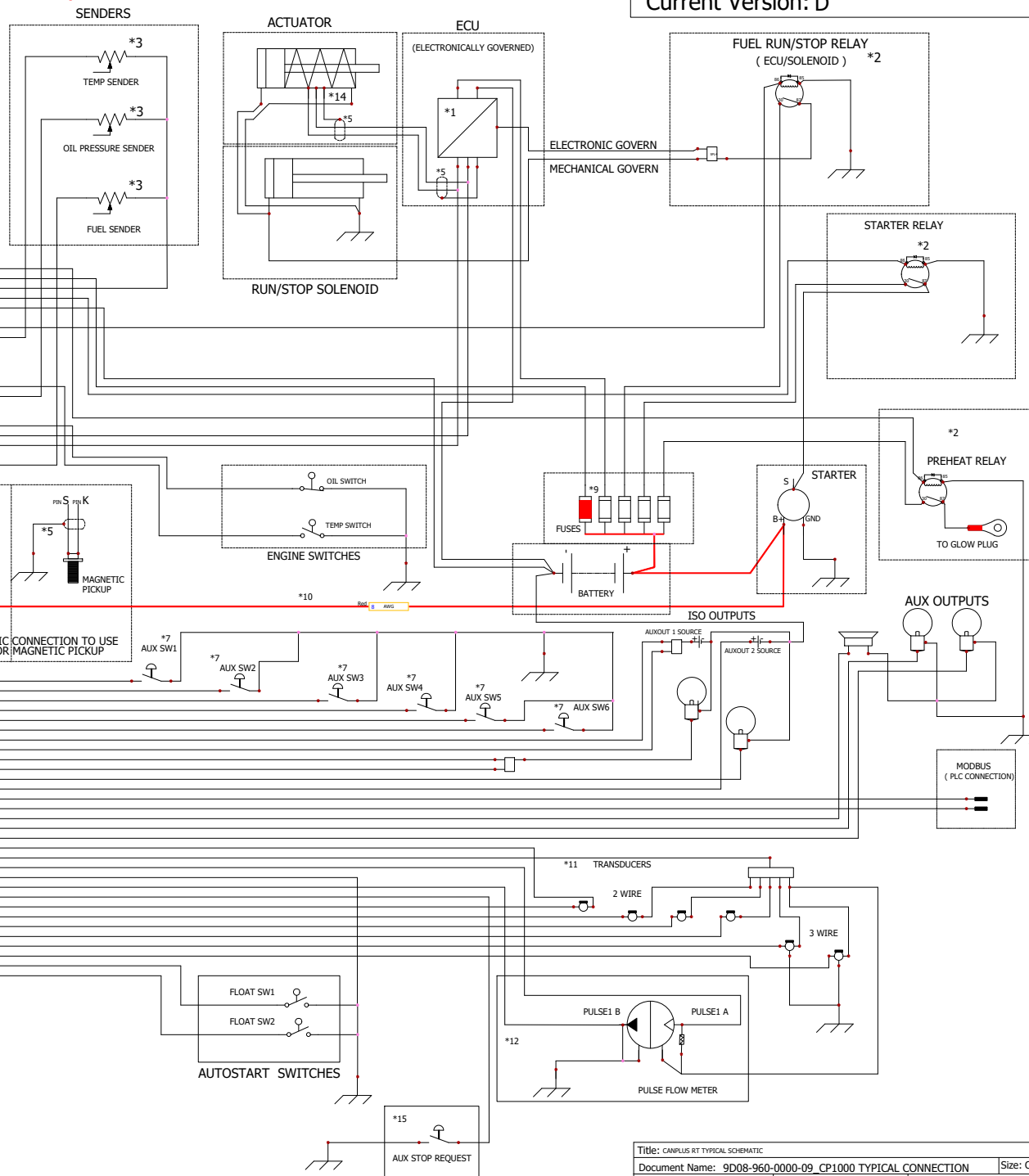

Title: CANPLUS RT TYPICAL SCHEMATIC		
Document Name: 9D08-960-0000-09 CP1000 TYPICAL CONNECTION	Size: C	
Sheet: 6 of 6	Date: 2/17/2020	DrawnBy: Al.Sarraf
<b>CATTRON NORTH AMERICA</b> 20 MANSELL CLE SUITE 350 ROSWELL, GA 30075 USA		