

PowerView™ - Model PV101-A, Version 2.3



Features

- For electronic engines and equipment applications using SAE J1939 Controller Area Network
- Displays over 50 standard SAE J1939 parameters broadcast by engine and transmission ECU's
- Displays active and ECU-stored faults with text description for diagnosing equipment malfunctions
- Simple connection to optional components

The **PowerView Model PV101**, Murphy's powerful display in the J1939 MurphyLink® family of components, provides a window into modern electronic engines and transmissions.

The PV101 display is a multifunction tool which enables equipment operators to view many standard engine and transmission parameters as well as active and stored trouble codes. The display can show either a single parameter or a quadrant display showing four parameters simultaneously. Diagnostic capabilities include codes with text translation for the most common fault conditions. The enhanced alarm indication has ultra-bright alarm and shutdown LEDs (amber and red). The PV101-A features include:

OEM Menu - This Password protected menu offers access to MODBUS Setup, Engine Speed Control ON/OFF, and other critical menu items that require restricted access.

Multiple language options - Russian, Czech, Brazilian Portuguese, Chinese, and Japanese models have been added to the line of existing languages (English, Spanish, French, German, and Italian).

Fuel Sender Input - select between backlight dimmer function or fuel level. Can be calibrated to use non-Murphy fuel senders.

Service Reminders - 5 service reminders allow users to set hours for: Change Engine Oil, Change Air Filters, Change Hydraulic Oil, Service Engine, and Service Machine.

Select Source Address - select the exact address the PV101 will claim on the Bus.

Select CANBUS Data Rate - allows user to select CANBUS data rate.

Other components in the MurphyLink system include micro-processor-based PowerView Analog (PVA) Gages for displaying critical engine data broadcast by an electronic engine or transmission's Engine Control Unit (ECU); engine RPM, oil pressure, coolant temperature, system voltage, and a combination audible alarm and relay unit for warning and shutdown annunciation. Up to 32 components may be linked to the PowerView using a simple daisy chain wire connection scheme using RS485. The PowerView and all connected components can be powered by either 12 or 24-volt systems.

Display Parameters

The following are some of the engine and transmission parameters displayed by the PowerView (when applicable, consult engine or transmission manufacturer for SAE J1939 supported parameters). The PowerView can display these parameters in all available languages, as well as in English or Metric units.

- | | | |
|------------------------------------|-----------------------------------|---|
| • Engine RPM | • Oil Pressure | • Transmission Oil Temperature |
| • Engine Hours | • Fuel Economy | • Transmission Gear Position |
| • Fuel Rate | • Throttle Position | • Active Service codes |
| • System Voltage | • Engine Manifold Air Temperature | • Stored Service Codes (when supported) |
| • % Engine Load at the Current RPM | • Current Fuel Consumption | • View Engine Configuration Parameters |
| • Coolant Temperature | • Transmission Oil Pressure | |
| • Catalyst Level | • NMEA 2000 GPS Parameters | |

Specifications

Operating Voltage

- 6.5 VDC minimum to 32 VDC maximum
- 8 VDC minimum to 32 VDC maximum with optional PVM gages

Reversed Polarity: Withstands reversed battery terminal polarity indefinitely within operating temperatures.

Environmental

Operating Temperature: -40 to +85°C (-40° to +185°F)
Display Viewing Temperature: -29 to +85°C (-20° to +185°F)
Storage Temperature: -40 to 85°C (-40° to +185°F)
Environmental Sealing: IP68, ±5 PSI (± 34.4 kPa)

Power Supply Operating Current

- @ 14VDC) 52 mA min; 300 mA max
- @ 32VDC) 1A max (with LCD heater)

CAN Bus: SAE J1939 compliant

Case: Polycarbonate / polyester

Maximum Panel Thickness: 3/8 inch (9.6 mm)

Product Dimensions

Auxiliary RS485 Communications Port

- User configurable as Modbus MASTER or Modbus RTU SLAVE
- MASTER ACTIVE (default) drives optional PVA or PVM gages
- SLAVE ACTIVE offers user adjustable communication parameters

Resistive Input: (user selectable as one of the following)

- Backlighting Potentiometer: 1 K Ohm, 1/4 W
- Murphy Fuel Sender: 33 Ohm full, 240 Ohm empty set from the factory or programmable to work with non-Murphy fuel senders

Fuel Sender Input: 33 Ohm full, 240 Ohm empty set standard from factory for use with Murphy Fuel sender. Programmable for use with non-Murphy fuel senders.

Shipping Weights (all models): 1 Lb. (450 g.)

Shipping Dimensions (all models):

- 5 x 6 x 6 in. (127 x 152 x 152 mm)

Clamp: PBT

Connectors: 6-pin Deutsch DT Series

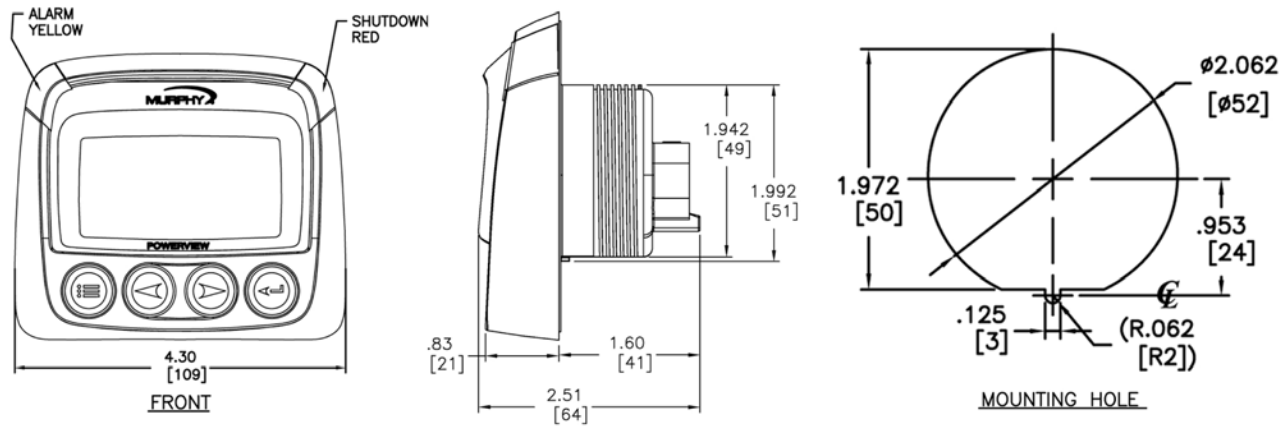

How to Order

Part Number	Model Number	Description	Languages Available
78700244	PV101-A	Murphy Standard	English, Spanish, French, Italian, German
78700396	PV101-A-M01	Murphy Standard Russian	English, Russian, French, German, Spanish
78700409	PV101-A-M02	Murphy Standard Chinese*	English, Chinese
78700411	PV101-A-M03	Murphy Standard Japanese*	English, Japanese

*Added features not available in these language models.

FW MURPHY

P.O. Box 470248
 Tulsa, Oklahoma 74147 USA
 Phone: +1 918 317 4100 Fax: +1 918 317 4266
 E-mail: sales@fwmurphy.com

INDUSTRIAL PANEL DIVISION

Fax: +1 918 317 4124
 E-mail: ipdsales@fwmurphy.com

MURPHY POWER IGNITION

Web site: www.murphy-pi.com

CONTROL SYSTEMS & SERVICES DIVISION

P.O. Box 1819
 Rosenberg, Texas 77471 USA
 Phone: +1 281 633 4500 Fax: +1 281 633 4588
 E-mail: ccs-solutions@fwmurphy.com

FRANK W. MURPHY LTD.

Church Road, Laverstock
 Salisbury, SP1 1QZ, UK
 Phone: +44 1722 410055 Fax: +44 1722 410088
 E-mail: sales@fwmurphy.co.uk
 Web site: www.fwmurphy.co.uk

FW MURPHY INSTRUMENTS (HANGZHOU) CO., LTD.

77 23rd Street
 Hangzhou Economic & Technological Development Area
 Hangzhou, Zhejiang, 310018, China
 Phone: +86 571 8788 6060 Fax: +86 571 8684 8878
 E-mail: apsales@fwmurphy.com



USA-ISO 9001:2008 FM 28221
 UK-ISO 9001:2008 FM 29422
 CHINA-ISO 9001:2008 FM 523851
 Registered Facilities

COMPUTRONIC CONTROLS

41 - 46 Railway Terrace
 Netchells, Birmingham, B7 5NG, UK
 E-mail: sales@computroniccontrols.com
 Web site: www.computroniccontrols.com



www.fwmurphy.com

05/05/2011