

LS200 & L1100 Series Liquid Level Switches

Electric Switch

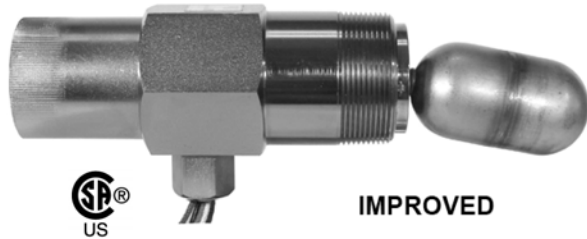

IMPROVED

LS200 Liquid Level Switches with 2" NPT mounting are float activated to operate an electrical SPDT snap switch (optional DPDT on some models) for alarm or shutdown of an engine or electric motor. The LS200 connects directly into the vessel wall and can be used with a Murphy weld collar (P/N 15050375) or Murphy external float chamber (P/N 15700799). L1100 models (1-1/2" NPT) are also available.

LS200NDVOR is a float-activated, pneumatic-vent level device used to operate dump valves or similar devices.

The LS200NDVOR provides a 2" NPT mounting with a pneumatic output for interfacing with pneumatic devices such as our Murphy pneumatic dump valve or with other pneumatic instrumentation.

LS200NDVO is the Dump Valve Operator (DVO) without the pressure regulator for those applications where the system provides a filter regulator for "instrument quality" air or gas as the control medium.

LS200N is the pneumatic level switch without the DVO and filter regulator.

NOTE: Pneumatic media devices require clean, dry, instrument quality air or gas. This unit is supplied with a pressure regulator, filter and Murphy 20BPG pressure gage for improved system life and trouble-free operation.

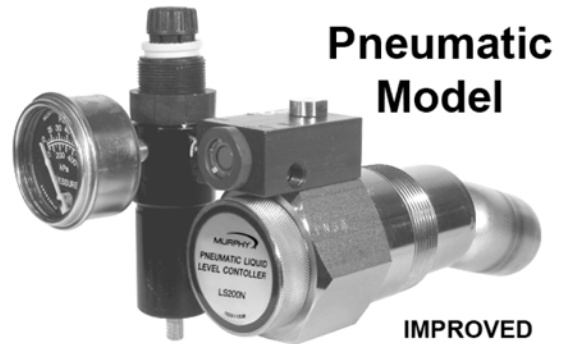

Pneumatic Model

IMPROVED

Features

- Designed for harsh gas compressor scrubber applications
- 304 stainless steel float operates in 0.55 specific gravity and heavier fluids (see Table 1)
- LS200 series rated for 2000 psi (13.8 MPa) [138 bar] working pressure
- Electric and pneumatic models available
- More robust design
- All models screw directly into the vessel or can be mounted via external float chamber
- Nickel plated body to provide enhanced corrosion protection
- Listed for Class I, Div. 1, Grp. C & D locations
- Canadian Registration Number OF1476.2
- Stainless Steel models are available for corrosive atmospheres.
- Trip on rising liquid level only

NOTE: The Murphy Series 1200 Liquid Level Switches are in the process of being replaced with the improved, more robust design of the Murphy LS200 Series Liquid Level Switches. The SLS (Scrubber Level System) which includes the high level switch, pneumatic level switch and DVU Dump valve will only be offered with the LS200 Series Switches, now available.

Accessories

Refer to LS200 Installation and Operations manual for additional information.

External Float Chamber 15700799

Operating Pressure: 2000psi (13.8MPa)[138 bar]

Operating Temperature: 400°F (204°C)

Weld Collar 15050375

Operating Pressure: 2000psi (13.8MPa)[138 bar]

Operating Temperature: 400°F (204°C)

Shipping Weight: 6 lb. (2.7kg)

Float Shaft Extension, 1", 15000478 (LS200 Series only)

Float Shaft Extension, 1", 15000892 (L1100 Series only)

Float Shaft Extension, 6", 15000503 (LS200 Series only)

Model	Float Extension length (inch)	Pressure (psi)	Specific Gravity
LS200	0	2000	0.55
	1		0.7
LS200NDVO	0	2000	0.63
	1		0.73

***Note:** The min. allowable SG will decrease with a decrease in operating pressure

Product Dimensions

LS200, L1100

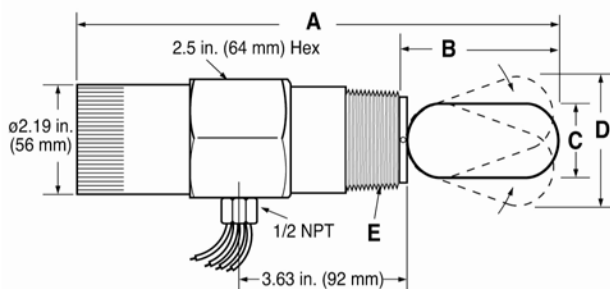

	LS200	L1100
A	10.16 in. (258 mm)	11 in. (279 mm)
B	3.44 in. (87 mm)	3.50 in. (189 mm)
C	1.75 in. (44 mm)	1.56 in. (40 mm)
D	2.80 in. (71 mm)	3.4 in. (71 mm)
E	2 NPT	1-1/2 NPT

Warranty - A limited warranty on materials and workmanship is given with this FW Murphy product. A copy of the warranty may be viewed or printed by going to <http://www.fwmurphy.com/warranty>

Application Data

Nom. Size (inches)	O.D. (inches)	Schedule Number	Wall Thickness (inches)	Inside Diameter (inches)
3	3.5	40ST	0.216	3.068
3	3.5	80XS	0.3	2.9
4	4.5	40ST	0.237	4.026
4	4.5	80XS	0.337	3.826

Product Name	Insertion Depth (inches)		Vertical Clearance (inches)	
	Std.	w/ 1" Extension	Std.	w/ 1" Extension
LS 200	4.6	5.6	2.8	3.15
LS 200N	5.43	6.4	3.3	3.9
L 1200	4.65	5.7	3.9	4.55
L 1200N	5.6	6.7	5.3	6.9
L 1100	4.4	5.4	3.4	4.05

LS200N, LS200NDVO and LS200NDVOR with Dump Valve Operator, Pressure Regulator & Gage

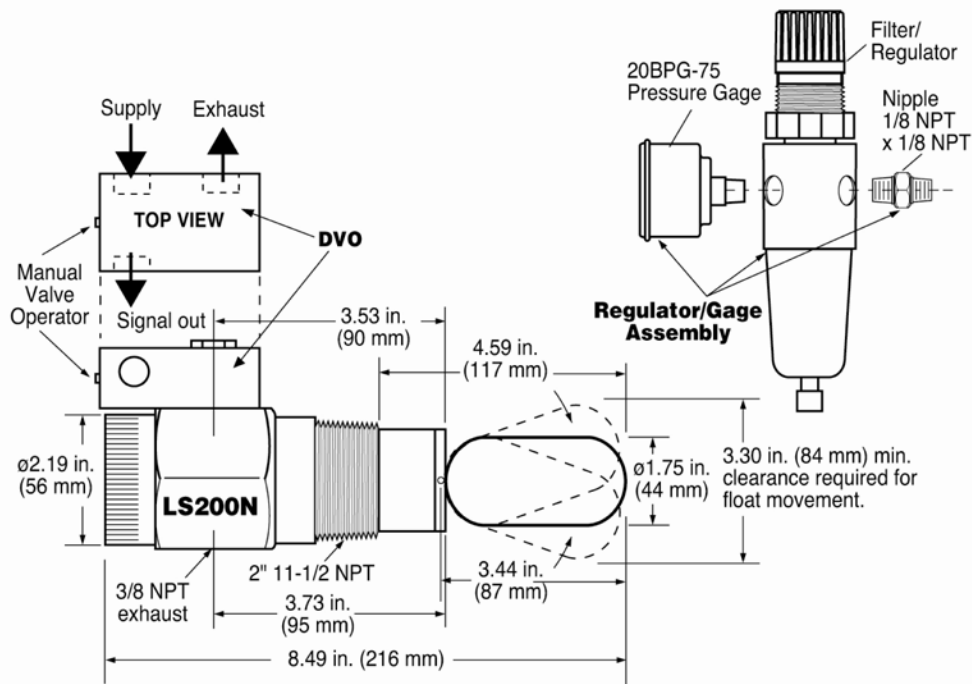

CAUTION: LS200 Series parts are not interchangeable with the L1200 Series.

Specifications

All Models

Body: Nickel plated steel; optional 316 stainless steel (meets NACE standard MR-01-75 for direct exposure to H₂S service)

Float: 304 stainless steel (see Table 1 for application data)

Pressure rating: 2000 psig (13.8 MPa) [138 bar] (LS200 models only)

O-ring: Viton

LS200

Process connection: 2" NPT

Temperature rating: -20 to 300°F (-29 to 149°C)

Electrical: SPDT std. (see "Electrical" section for configuration/rating).

Wiring: 18 AWG x 36 in. (1.0 mm² x 916 mm)

LS200NDVOR

Process connection: 2" NPT

DVO valve: 3 way N.C. w/manual operator, all connections 1/8" NPT (minimum 30 psig required)

Filter/pressure regulator set:

Regulator: 0 to 75 psig (0 to 517 kPa) [0 to 5.17 bar] range

Maximum input pressure: 300 psig (2.07 MPa) [20.7 bar]

LS200NDVO

Process connection: 2" NPT

DVO valve: 3 way N.C. w/manual operator; all connections 1/8" NPT

LS200 --

Options:
 D = DPDT
 K = KALREZ Seals
 400 = 400°F (204°C) Service **
 SF - Stainless Steel Float (L1100 only)

Base Models:

LS200*	LS200SS*
LS200N*	LS200NSS*
LS200NDVO*	LS200NSSDVO*
LS200NDVOR*	LS200NSSDVOR*
L1100**~	
L1111	

LS200 N

Process connection: 2" NPT

Vent valve: 2 way N.C. w/ 1/16in. (2mm) orifice and Viton seat; Inlet: 1/8" NPT; outlet 3/8" NPT

L1100

Process connection: 1-1/2" NPT

Pressure rating: 1500 psig (10.3 MPa) [103.2 bar]

Float: BUOYGLAS™ operates to 0.5 specific gravity; Optional stainless steel to operate in 0.65 specific gravity

Electrical: SPDT switch

Approximate Shipping Weights and Dimensions

All models: 6 lb. 10 oz. (3 kg);

14 x 5 x 3-1/2 in. (356 x 127 x 89 mm)

Electrical

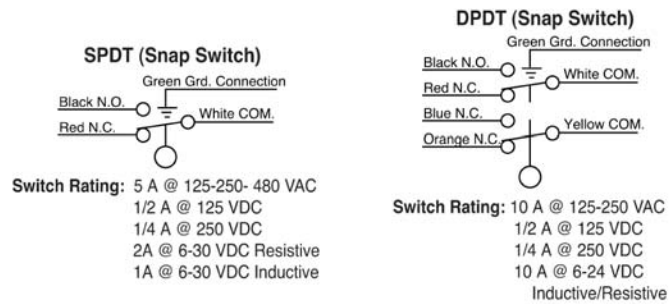

How to Order your Level Switch

Build a complete model number using the diagram to the left.
 NOTE: Refer to LS-04006N for replacement parts.

*Pending Canadian Registration Number OF1476.2 issued by ABSA.

**Not available with DPDT snap-switch.

~Supplied with BUOYGLAS™ float.